

Innovation 2013

LEICHT®

HANDLE-LESS CARCASE CONCEPTS

LEICHT adds to and extends the Collection 2013 with new handle-less programmes, offering its partners the most comprehensive range for a handle-less kitchen arrangement in price and style.



CONTINO

The name is the programme. The carcass line CONTINO stands for continuity during the further development of handle-less kitchens. LEICHT is introducing a grip-rail concept which shows the 80cm carcass in a new layout. The upper grip-rail of the drawer is positioned immediately below the worktop. The lower grip-rail is at the bottom of the lower drawer 46 cm from the top. The grip-rail for tall units lies at 150 cm as with AVANCE.

Constructional alterations, optimising the carcass concept, resulted in a new price situation. This includes the standard fitting of a favourably priced frame for drawers and pull-outs, for instance without the chamfered edge to grip at the rear of the front, as used with the AVANCE.



CONTINO wall units have a standardised integrated handle profile, thus the LEICHT standard-front dimensions can be used.

In the CONTINO-Collection, familiar names of the LEICHT programme are being used. There is an added “-C” (for example: CERES-C). All changeable programmes will be available at the start of the Collection 2013.

AVANCE PRO

The design-avant-garde among the handle-less kitchens is the new carcass concept AVANCE pro together with the programme CORE. The "Core" front is constructed as a two layer front. The 4mm thick compact laminate is doubled up on a 16 mm thick aluminium-edged support frame in such a way, that it creates a front overhang in the grip area, serving as a grip edge. This thinness is detected by sensors during opening of doors and pull-outs. The support remains hidden by the projecting grip rail. Correspondingly vertical grip rails with the same system are used for tall units. This front arrangement highlights the particularly elegant and contoured appearance and charisma of the AVANCE pro.



The visible and minimally chamfered compact-laminate clearly enhances the fronts. In order to reflect this striking contour of the graining even more and to emphasise it more clearly, the vertical joints have been reduced by 1 mm.



The plain silk-matt surface captures the spirit of the times and accentuates the minimalistic, sensual elegance of the programme.

CORE is available from January 2013:

K 100 arctis
K 120 frosty white
K 130 mohair
K 136 sand grey



PROGRAMMES

New, very different and particularly independent programmes are highlights of the Collection 2013.



STRATO

Programme No. 223, price group 02

A particularly lively surface effect characterises the programme STRATO. The melamine resin covered laminate front in a plain colour, is raised on the face with a tactile feel and has a seamlessly lasered thick edge. Two alternatives are available: "surf" shows a slightly wavy texture whilst "patch" has a vertical-horizontal combination, giving the surface a more textile effect.

STRATO is available in two textures each in two colours:

K 208v frosty patch (see picture) K 212v sand grey patch
K 209h frosty white surf K 213h sand grey surf



TETIS

Programme No. 250, price group 03

Corresponding to the AMICA, the TETIS laminate front, faced with a high quality laminate, has a seamlessly lasered plastic thick edge all round. It represents a special quality of edge work. The front face in plain high gloss, the reverse colour matching and matt textured.

The programme TETIS is available in five colours (not with glass effect edge):

KG 032 magnolia KG 120 frosty white KG 136 sand grey
KG 100 arctis KG 130 mohair



XYLO

Programme No. 257, price group 06

A wood veneer programme with a strong brushed oak veneer, giving a pronounced aged wood effect in form of ingrown branches and cracks. The veneer faces are vertically matching. Staggered joints emphasise the authentic character. Solid wood edge glued all round. Environment friendly water based stain and PUR-lacquer seal.

The following near natural colours are available:

HI 374v aged oak natural HI 376v aged oak slate
HI 375v alteiche kupfer HI 377v aged oak moor

COLOURS

New colours offer additional scope for harmonious tone-in-tone or contrasting colour combinations.

RETRO-TREND COLOURS

With a composition of strong colourful colours, typical Retro-trend colours of the fifties, sixties and seventies, LEICHT has expanded the Collection 2013 with an interesting feature. This is meant for colour highlighting or rhythmic separation of furniture or living room elements. Also pleasing in combination with classics of the modern design history. Curcuma, saffron and petrol are available in all matt and finely textured programmes, in FS, FF and LR.

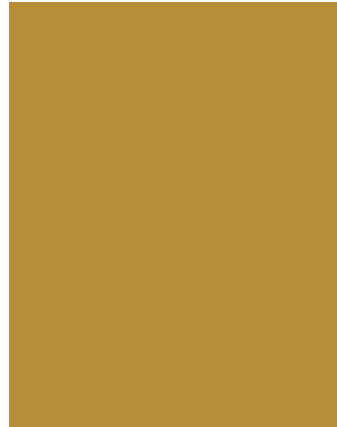

156 curcuma



157 saffron

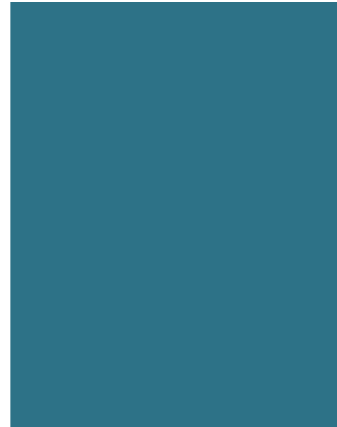

158 petrol

MOHAIR

The new colour mohair is available in K, KG, BG, FF, FS, FS GL, GM (in KANTO also). LEICHT extends the plain colour range of warm grey tones with mohair, in response to the growing need of the trade for light grey tone combination colours. A subtle yellow-red hue is visible in mohair, which is neutral enough in order to combine with most plain colours of the Collection. Above all it ideally complements almost all wood veneer and reproduction fronts.

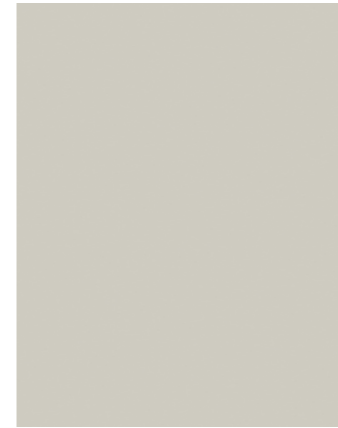

130 mohair

NEW WOOD COLOURS

So as to offer the best comprehensive colour match within the wood veneer programme range, the following colours are added to existing programmes. Here exclusively water based stains and lacquers are used:



H 314 h textured oak slate



H 316h textured oak moor



H 324v slate oak coarse

WORKTOPS

A further expanded worktop range with new colours in the material field, mineral solid surfaces, ceramics, laminate and glass, together with additional work top thicknesses, has widened the scope for creativity.

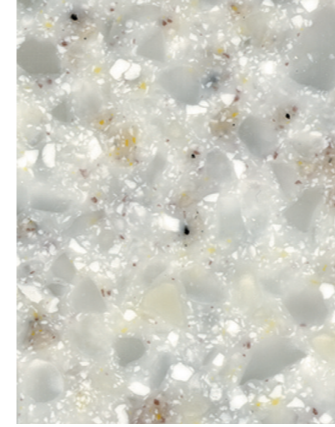

552 quarz pergament



558 quarz cement

MINERAL BASED MATERIAL

Worktops of mineral based material of the brand HIMACS in the thickness of 1,2 cm, 4 cm and 6 cm are new in the LEICHT Collection 2013. To match, single sided panels in worktop thickness, rear wall panels and seamlessly glued-under bowls with stainless steel base are available.

CERAMIC

Two iridescent, steel-type colours have been added to the existing ceramic collection:



547 polar

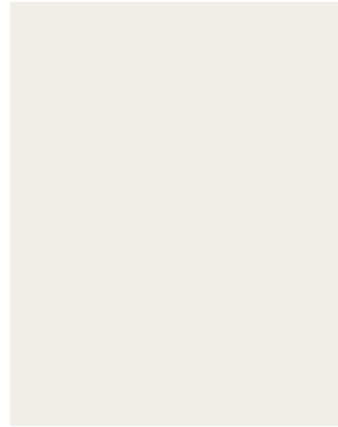

551 parchment

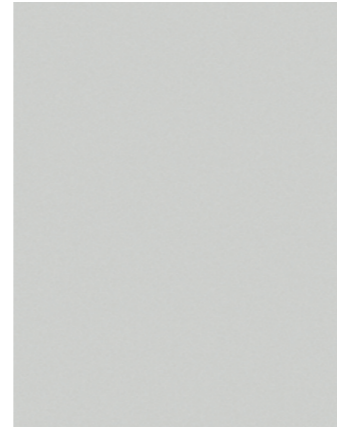

556 concrete



687 stromboli



688 kiruna



557 pearl

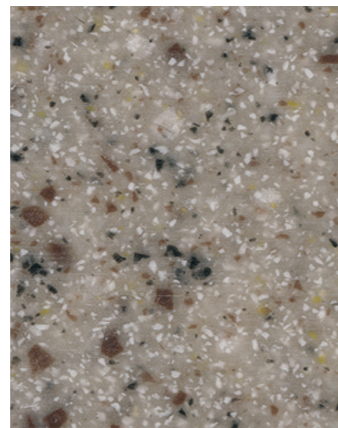

561 cement

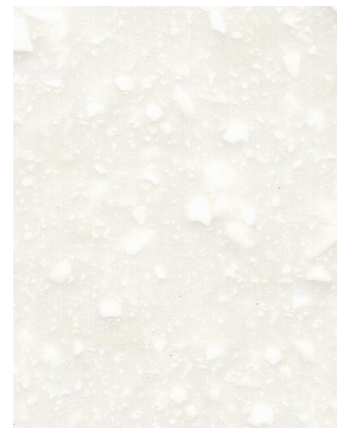

548 quartz frost

QUARTZ MATERIAL

Three colours have been added to the quartz material collection:



572 alba



603 taiga

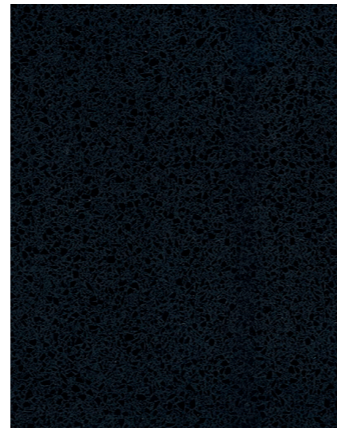

604 tenegua

LAMINATE

For a homogenous colour arrangement of fronts and worktops, the new colour mohair is available also for worktops.

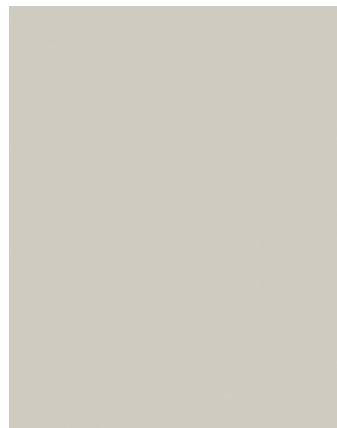

130 mohair

LAMINATE WORKTOP AP 3

An additional worktop thickness for all K- and KH decors of 3 cm. Edge versions KD, MG and MG is available (excluding the RR edge).

LAMINATE WORKTOP AP 6 WITH KD EDGE

All K- and KH-decors in 6 cm are available with KD-edge with the start of the Collection. Side panels W6 and shelves B6 are also available.

Compact laminate worktop AP KP 1

Extremely robust but elegant, the new solid compact laminate worktops in 1 cm thickness have a visibly milled dark core. Four colours are available, matching for choice in the programme CORE/AVANCE pro.

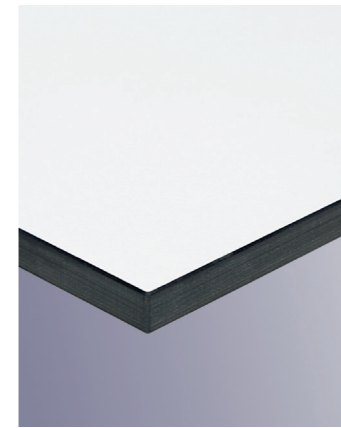

100 arctis

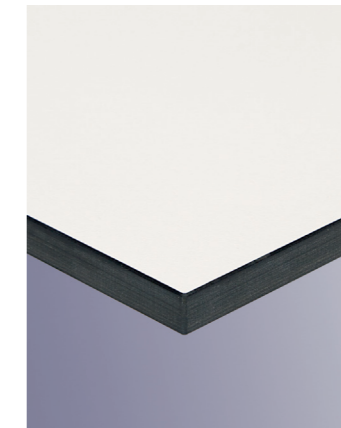

120 frosty white

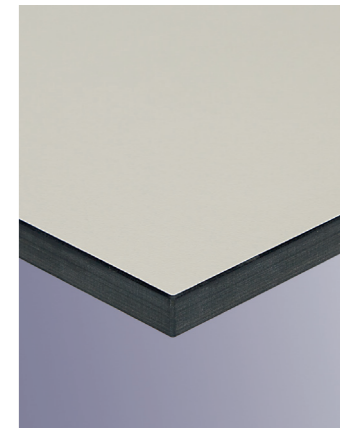

130 mohair

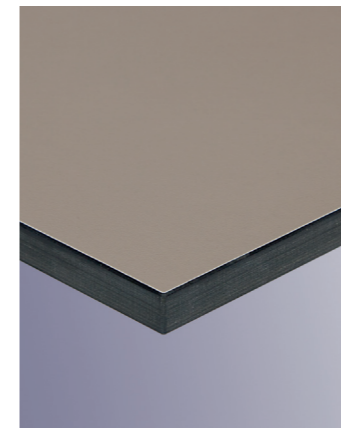

136 sand grey



GLASS WORKTOP AP GL 1

The new glass worktop is only 1,3 cm thick. It is supplied without additional support panel in depths of up to 120 cm. On the underside the worktop is protected against scratches by a lay.

As usual, glass worktops without support structure are available in all RAL Classic colours. Complementing glass side panels are available in 0,6 and 1,2 cm.

HANDLES

New handle versions from classic to functional, ergonomic and pleasant to the touch, allow for an individual front arrangement, meeting all customer requirements.



379.301 bow handle (LEICHT | KANTO)

A classic handle with encased feet for framed doors such as CARRE-FS or CASTELLO-2-FS.

Drill hole spacing 160, height 29, pewter colour.

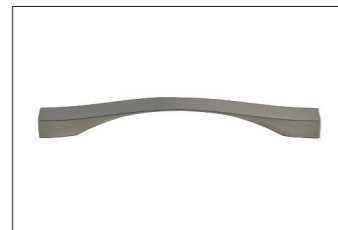

393.405 Bow handle (LEICHT | KANTO)

Handle with square end, slender in the grip area and ergonomically formed.

Drill hole spacing 160, height 25, stainless steel colour.

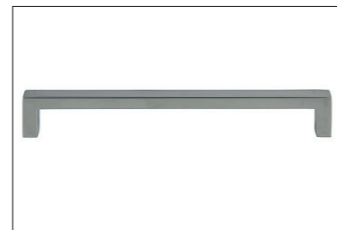

588.413 bow handle (LEICHT)

Plain, functional handle, already familiar from the metal framed doors.

Drill hole spacing 192, height 32, alu coloured.

CUPBOARD MODULES

With the introduction of new cupboard types and numerous additions and improvements in the details, the new Collection offers an even wider range of exclusive planning and design ideas.

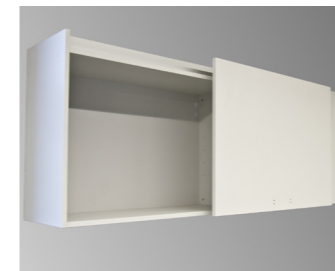

Flush sliding doors-wall unit OS2

A new sliding door cupboard, specifically designed for generous wall unit layouts. Available in the widths 120 cm, 160 cm and 180 cm and in all heights from 53 cm to 93 cm. Consisting of two carcasses and fixing for fitting two fronts on one level. The fronts slide past each other. The use of form- and profile bars, handles up to a height of 36 cm and handle-less planning for AVANCE and CONTINO are possible.

OS-cupboards in further heights (also for KANTO)

The single run sliding doors wall units are now also available in the heights of 66 cm, 80 cm and 93 cm.

Wall unit 119 cm

Additional wall units in a height of 119 cm have been added so as to make possible room high layouts. They are also available for AVANCE and CONTINO.

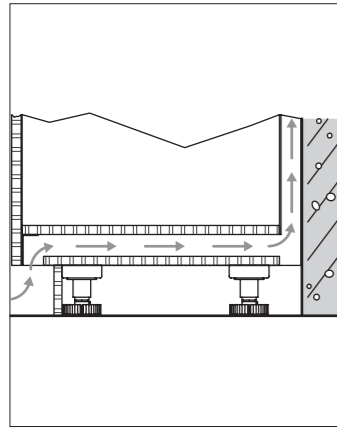

GU with integrated ventilation (also for KANTO)

Housing units are fitted with integrated ventilation via the alteration key AN INDB. The ventilation space between the double shelves is covered with a blender.

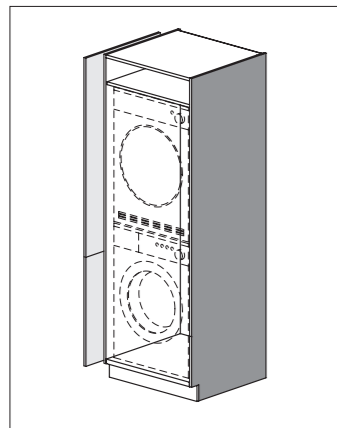

Slide- away door cupboard for washing machines H7EWMU 70

Slide-away door cupboard for two appliances with sides down to the floor, recessed at the bottom for continuation of the plinth cover. The appliances stand on a separate appliances plinth, uncoupled for noise reduction. Interior arrangement as required. Only available in 68 cm depth.

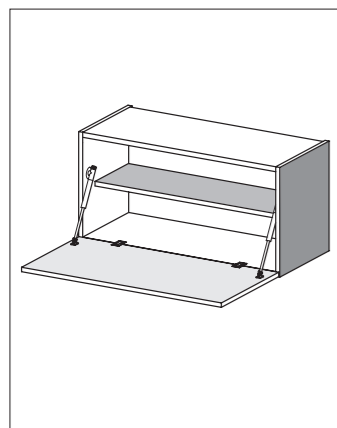

Bar flap cupboards

A new bar flap cupboard, 40 cm high, with the flap down and a flush fitting flap hinge, is available as a free hanging sideboard cupboard or as Paneel 40-cupboard element.

**TOK 60/40, TOK 80/40, TOK 90/40, TOK 100/40
PW BKL 80/40, PW BKL 90/40, PW BKL 100/40**



Lift-up door wall unit

The lift-up hinges are being changed uniformly to BLUM Aventos. This results in type-extensions and alterations.

The 27 cm height will be complemented by the width 120 cm: **OA 120/27**

The 53 cm height is new: **OK 30 – 120/53,**

for AVANCE and CONTINO: **OK 50 – 120/53 A, OK 50 – 120/53 C**

The hinge combination for the touch-opening is also changed. Here we have a new handle number: **774.000.** The touch opening solution is in future also available for lift-up doors up to 120 cm.



Centre side panel for panel shelf units

1,6 cm thick centre panels with a rear wall shank are now available as a colour contrast and as divisions of side panel shelf units for subsequent adjustments. They are available in the widths of 30 cm and 60 cm or variable and are always adapted to the true shelf height. Softening profiles to upper and lower edges protect from scratches during sliding in and supply the typical shadow joint. The front edge of the angled middle panel is recessed by 4 cm. The maximum shelf depth is 36 cm.

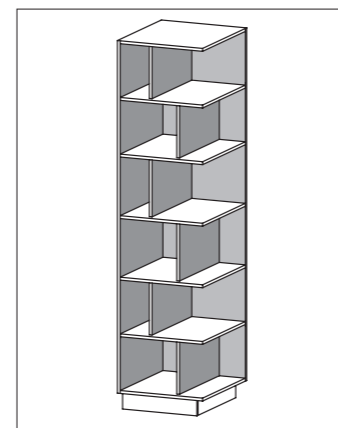

Sliding- in and end shelf units in 16 mm

The new shelf unit series in 1.6 cm thickness provides a homely ambience. End shelf units with a deliberate square, rectangular corner arrangement for wall, floor and tall units in varying widths of 10 cm up to 60 cm are included. From a width of 40.1 cm with staggered middle side shelves which may also be colour contrasting as required.

Examples: **UAR 40/8 OAR 60/53 HOARM 60**

Isle end shelf units are also available in depths of 90 cm up to 120 cm and widths from 10 cm up to 60 cm, generally with staggered middle sides in all widths.

Example: **IAR 40**

New slide-in shelf units are also available for the integration into cupboard runs. Here the middle sides including fixing are supplied loose for onsite positioning. **EREM ...**

Type extension for waste disposal units

Various new waste disposal and sink units with two pull-outs and 40 cm division are now available:

T 30/8 Z2W, T 45/8 Z2W, T 50/8 Z2W T 60/8 Z2W, TSP 50/8 Z2W, TSPG 60/8 Z2W, TSPG 50/8 Z2W, TSPG 60/8 Z2W, For AVANCE: TSPG 60/8 Z2WA

KANTO type extension

Visible sides in KANTO can now be ordered via alteration key AN FSK (extra charge).

Two swing-up door cupboards have also been added to the KANTO programme:

OSK 100/53

OSK 100/66

ACCESSORIES

A functional and sophisticated interior arrangement of drawers and pull-outs, varying in material and design, will enhance every kitchen.



Wood Sound

Wood sound is an audio-system for Apple appliances, consisting of a docking station inserted into a top and an amplifier for positioning in the cupboard. Loudspeakers have to be supplied on site by the customer.



Q-Box/Q-Vario Innenausstattung

LEICHT is introducing a new organisation system for drawers and pull-outs under the name of "Q-Box/Q-Vario". Classically modern and of high quality in appearance, flexible and functional in practice.

The "Q" (in English: "kyoo") is the inspiration for a new interior arrangement system. "Q" is synonymous with "queue" (= standing in line, fitting in) and therefore representative of the modularity of the system. "Q" phonetically means "cubic" = volume in the sense of optimal use of space.

Q-Box means the interior furnishing of drawers, Q-Vario is the division of the pull-outs.

Q-Box is the cutlery tray of solid oak with form-fitting, hard elastic profile trays of carbon appearance. They are cushioning and anti-slip at the same time. The height increased, flush material transition from profile tray to the wooden bridge is particularly elegant. The dividing joint is no longer susceptible to dirt. The profile trays can be removed for cleaning.

Function elements such as the knife block and foil dispenser can be inserted as required. The range also includes tightly closing porcelain jar sets of 5 or 10 pieces. Q-Box is available for all standard carcass depths.

Perforated grids and dividing boards in oak are used for the Q-Vario arrangement. If required, the holes can be covered with the enclosed anti-slip mats, for instance for storing pots in the pull-outs. There is also a felt covered lid compartment. Further functions are: bottle holder, plate holder and glasses.

DESIGN ELEMENTS

LEICHT design elements offer the trade the highest degree of individuality and independence in planning and are therefore unique.



Accent glass

Accent glass cupboards have an additional door version in satin finished Opti-white glass and frame rear print in white.



AMBIENCE xtend

xtend is the further development of the internally illuminated AMBIENCE cupboards towards an open elegantly contoured light shelf unit. Set on the worktop, it serves the open arrangement of the work place and, thanks to its light appearance, making it an interior architectural eye catcher. Free standing and through its transparency and its clearly arranged light-flooded structure, it creates a homely atmosphere in the room.

The design of xtend combines technical progress with the homeliness of the furniture surfaces. The supporting elements of stainless steel coloured aluminium produce a slender but sturdy construction. They also carry the entire LED-lighting technology. Bearer supports serve to connect the shelf stalls and to hold the shelves. They are height adjustable thanks to the shelf supports in the verticals which can be locked in any required height. The type of shelf can be chosen from the entire colour and material range.

High quality chip-on-board LEDs with a colour rendering index of > 95, integrated in the shelf front edge, ensure the natural illumination and colour effect of all surfaces. As in the AMBIENCE cupboards, the shelves can be positioned in any desired height thanks to the spring loaded contact pins.

The dimensionally flexible shelf unit system of an add-on type consists of 1.6 cm thick stands and shelves. All front edges are in aluminium. The added strengths of the verticals have to be taken into consideration as also the true space between them, when planning. A wall fixed or a free standing version is available to choice.

Available from January 2013.

TECHNOLOGY

A continuous product review ensures that LEICHT kitchens are always technically up-to-date.



Electrical pull-out opener HFO

Hands-free door opening – that meets the desire of the comfort seeking kitchen customer. A new electrically operated pull-out opener is intended mainly for installation in sink and waste disposal units. The electrical unit is fitted into the lower construction shelf and contains the ejector together with a sensor with orientation light for operating by foot. This requires a recessed plinth.

Synchronous control for pull-outs (also for KANTO)

A synchronous control can be added to the cupboard, in order to optimise the parallel run of pull-outs from width 80 cm. Here the sides are pre-drilled in the factory and the fitting supplied loose for fitting on site.

Cushioned Le Mans shelves (also for KANTO)

The optional cushioning **LM D** for Le Mans shelves can be subsequently installed in cupboards from Collection 2013 onwards.

LEICHT Küchen AG
Postfach 60
73548 Waldstetten
Germany
Phone +49 | 7171 | 402-0
Fax +49 | 7171 | 402-300
www.leicht.com